

SECTION **FSU**
FRONT SUSPENSION

A
B
C
D
E
F
G
H
I
J
K
L
M
N
O
P

FSU

CONTENTS

SYMPTOM DIAGNOSIS	2	TRANSVERSE LINK	10
NOISE, VIBRATION AND HARSHNESS (NVH) TROUBLESHOOTING	2	Removal and Installation	10
NVH Troubleshooting Chart	2	FRONT STABILIZER	11
PRECAUTION	3	Removal and Installation	11
PRECAUTIONS	3	STEERING KNUCKLE	12
Precaution for Supplemental Restraint System (SRS) "AIR BAG" and "SEAT BELT PRE-TENSIONER"	3	Removal and Installation	12
Precautions Necessary for Steering Wheel Rotation after Battery Disconnect	3	REMOVAL AND INSTALLATION	13
Service Notice or Precautions	3	FRONT SUSPENSION ASSEMBLY	13
PREPARATION	5	Exploded View	13
PREPARATION	5	Removal and Installation	14
Special Service Tool	5	DISASSEMBLY AND ASSEMBLY	15
Commercial Service Tool	6	FRONT COIL SPRING AND STRUT	15
ON-VEHICLE MAINTENANCE	7	Disassembly and Assembly	15
FRONT SUSPENSION ASSEMBLY	7	Inspection	16
Inspection and Adjustment	7	SERVICE DATA AND SPECIFICATIONS (SDS)	17
ON-VEHICLE REPAIR	9	SERVICE DATA AND SPECIFICATIONS (SDS)	17
FRONT COIL SPRING AND STRUT	9	Wheel Alignment (Unladen*)	17
Removal and Installation	9	Ball Joint	17
		Wheelarch Height (Unladen*1)	18

NOISE, VIBRATION AND HARSHNESS (NVH) TROUBLESHOOTING

< SYMPTOM DIAGNOSIS >

SYMPTOM DIAGNOSIS

NOISE, VIBRATION AND HARSHNESS (NVH) TROUBLESHOOTING

NVH Troubleshooting Chart

INFOID:000000003895016

Use the chart below to help you find the cause of the symptom. If necessary, repair or replace these parts.

Reference page		FSU-13	FSU-16	—	—	—	FSU-13	FSU-7	FSU-7	WT-57, "NVH Troubleshooting Chart"	WT-57, "NVH Troubleshooting Chart"	FAX-2, "NVH Troubleshooting Chart"	BR-5, "NVH Troubleshooting Chart"	ST-8, "NVH Troubleshooting Chart"
Possible cause and SUSPECTED PARTS		Improper installation, looseness	Shock absorber deformation, damage or deflection	Bushing or mounting deterioration	Parts interference	Spring fatigue	Suspension looseness	Incorrect wheel alignment	Stabilizer bar fatigue	TIRES	ROAD WHEEL	DRIVE SHAFT AND WHEEL HUB	BRAKES	STEERING
Symptom	Noise	x	x	x	x	x	x			x	x	x	x	x
	Shake	x	x	x	x		x			x	x	x	x	x
	Vibration	x	x	x	x	x				x		x		x
	Shimmy	x	x	x	x			x		x	x		x	x
	Shudder	x	x	x						x	x		x	x
	Poor quality ride or handling	x	x	x	x	x		x	x	x	x			

x: Applicable

PRECAUTIONS

< PRECAUTION >

PRECAUTION

PRECAUTIONS

Precaution for Supplemental Restraint System (SRS) "AIR BAG" and "SEAT BELT PRE-TENSIONER"

INFOID:000000003895017

The Supplemental Restraint System such as "AIR BAG" and "SEAT BELT PRE-TENSIONER", used along with a front seat belt, helps to reduce the risk or severity of injury to the driver and front passenger for certain types of collision. This system includes seat belt switch inputs and dual stage front air bag modules. The SRS system uses the seat belt switches to determine the front air bag deployment, and may only deploy one front air bag, depending on the severity of a collision and whether the front occupants are belted or unbelted. Information necessary to service the system safely is included in the SR and SB section of this Service Manual.

WARNING:

- To avoid rendering the SRS inoperative, which could increase the risk of personal injury or death in the event of a collision which would result in air bag inflation, all maintenance must be performed by an authorized NISSAN/INFINITI dealer.
- Improper maintenance, including incorrect removal and installation of the SRS, can lead to personal injury caused by unintentional activation of the system. For removal of Spiral Cable and Air Bag Module, see the SR section.
- Do not use electrical test equipment on any circuit related to the SRS unless instructed to in this Service Manual. SRS wiring harnesses can be identified by yellow and/or orange harnesses or harness connectors.

Precautions Necessary for Steering Wheel Rotation after Battery Disconnect

INFOID:000000004394041

NOTE:

- Before removing and installing any control units, first turn the push-button ignition switch to the LOCK position, then disconnect both battery cables.
- After finishing work, confirm that all control unit connectors are connected properly, then re-connect both battery cables.
- Always use CONSULT-III to perform self-diagnosis as a part of each function inspection after finishing work. If a DTC is detected, perform trouble diagnosis according to self-diagnosis results.

This vehicle is equipped with a push-button ignition switch and a steering lock unit.

If the battery is disconnected or discharged, the steering wheel will lock and cannot be turned.

If turning the steering wheel is required with the battery disconnected or discharged, follow the procedure below before starting the repair operation.

OPERATION PROCEDURE

1. Connect both battery cables.

NOTE:

Supply power using jumper cables if battery is discharged.

2. Carry the Intelligent Key or insert it to the key slot and turn the push-button ignition switch to ACC position. (At this time, the steering lock will be released.)
3. Disconnect both battery cables. The steering lock will remain released with both battery cables disconnected and the steering wheel can be turned.
4. Perform the necessary repair operation.
5. When the repair work is completed, re-connect both battery cables. With the brake pedal released, turn the push-button ignition switch from ACC position to ON position, then to LOCK position. (The steering wheel will lock when the push-button ignition switch is turned to LOCK position.)
6. Perform self-diagnosis check of all control units using CONSULT-III.

Service Notice or Precautions

INFOID:000000003895018

- When installing rubber bushings, the final tightening must be carried out under unladen conditions with tires on ground. Oil might shorten the life of rubber bushings. Be sure to wipe off any spilled oil.
- Unladen conditions mean that fuel, engine coolant and lubricant are full. Spare tire, jack, hand tools and mats are in designated positions.

PRECAUTIONS

< PRECAUTION >

- After servicing suspension parts, be sure to check wheel alignment.
- Self-lock nuts are not reusable. Always use new ones when installing. Since new self-lock nuts are pre-oiled, tighten as they are.

PREPARATION

< PREPARATION >

PREPARATION

PREPARATION

Special Service Tool

INFOID:000000003895019

The actual shapes of the Kent-Moore tools may differ from those of special service tools illustrated here.

Tool number (Kent-Moore No.) Tool name	Description
HT7252000 (J-25730-A) Ball joint remover	Removing tie-rod outer and lower ball joint
ST3127S000 (J-25765-A) Preload gauge	Measuring ball joint sliding torque
KV991040S1 (—) CCK gauge attachment <ol style="list-style-type: none"> 1. KV99104020 Adapter A 2. KV99104030 Adapter B 3. KV99104040 Adapter C 4. KV99104050 Adapter D 5. KV99104060 Plate 6. KV99104070 Guide bolt 7. KV99104080 Spring 8. KV99104090 Center plate 	Measuring wheel alignment
ST35652000 (—) Strut attachment	Disassembling and assembling strut

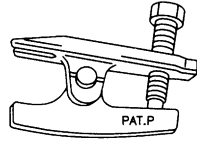

S-NT146

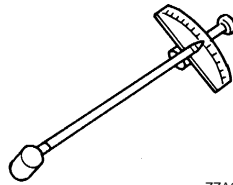

ZZA0806D

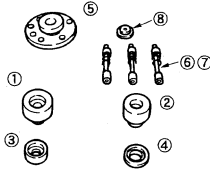

ZZA1167D

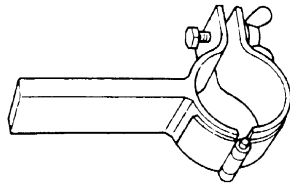

ZZA0807D



A
B
C
D
FSU
F
G
H
I
J
K
L
M
N
O
P

PREPARATION

< PREPARATION >

Commercial Service Tool

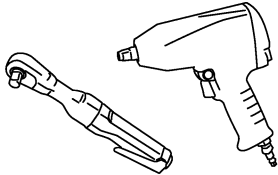
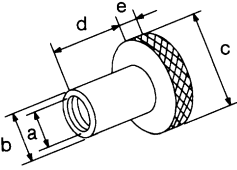
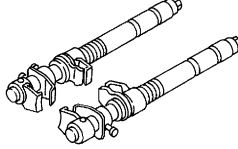
INFOID:000000003895020

Tool name	Description
<p>Power tool</p>  <p>PBIC0190E</p>	<p>Loosening bolts and nuts</p>
<p>Attachment wheel alignment</p> <p>a: screw M24 x 1.5 pitch b: 35 mm (1.38 in) dia. c: 65 mm (2.56 in) dia. d: 56 mm (2.20 in) dia. e: 12 mm (0.47 in) dia.</p>  <p>NT148</p>	<p>Measuring wheel alignment</p>
<p>Spring compressor</p>  <p>NT717</p>	<p>Removing and installing coil spring</p>
<p>Engine slinger</p>  <p>LEIA0062E</p>	<p>Removing and installing suspension member with VQ35DE and CVT</p>

FRONT SUSPENSION ASSEMBLY

< ON-VEHICLE MAINTENANCE >

ON-VEHICLE MAINTENANCE

FRONT SUSPENSION ASSEMBLY

Inspection and Adjustment

INFOID:000000003895021

INSPECTION

Make sure the mounting conditions (looseness, backlash) of each component and component conditions (wear, damage) are normal.

LOWER BALL JOINT END PLAY

1. Set front wheels in a straight-ahead position. Do not depress brake pedal.
2. Place an iron bar or similar tool between upper link and steering knuckle.
3. Measure axial end play by prying it up and down. Refer to [FSU-17, "Ball Joint"](#).

CAUTION:

Be careful not to damage ball joint boot. Do not damage the installation position by applying excessive force.

SHOCK ABSORBER

Check for oil leakage, damage and replace if malfunction is detected.

WHEEL ALIGNMENT

Description

Measure wheel alignment under unladen conditions.

NOTE:

"Unladen conditions" means that fuel, engine coolant, and lubricant are full. Spare tire, jack, hand tools and mats are in designated positions.

General Information and Recommendations

- A four-wheel thrust alignment should be performed.
- This type of alignment is recommended for any NISSAN vehicle.
- The four-wheel "thrust" process helps ensure that the vehicle is properly aligned and the steering wheel is centered.
- The alignment rack itself should be capable of accepting any NISSAN vehicle.
- The rack should be checked to ensure that it is level.
- Make sure the machine is properly calibrated.
- Your alignment equipment should be regularly calibrated in order to give correct information.
- Check with the manufacturer of your specific equipment for their recommended Service/Calibration Schedule.

Preliminary Check

Check the following:

1. Tires for improper air pressure and wear.
2. Road wheels for runout. Refer to [WT-66, "Road Wheel"](#).
3. Wheel bearing axial end play. Refer to [FAX-27, "Wheel Bearing"](#).
4. Transverse link ball joint axial end play. Refer to [FSU-10, "Removal and Installation"](#).
5. Shock absorber operation.
6. Each mounting part of axle and suspension for looseness and deformation.
7. Each of suspension member, shock absorber, upper link and transverse link for cracks, deformation and other damage.
8. Vehicle height (posture).

Alignment Process

IMPORTANT:

Use only the alignment specifications listed in this Service Manual.

- When displaying the alignment settings, many alignment machines use "indicators" **Do not use these indicators.**: (Green/red, plus or minus, Go/No Go).
- The alignment specifications programmed into your machine that operate these indicators may not be correct.

A
B
C
D
E
F
G
H
I
J
K
L
M
N
O
P

FSU

FRONT SUSPENSION ASSEMBLY

< ON-VEHICLE MAINTENANCE >

- This may result in an ERROR.
- Some newer alignment machines are equipped with an optional "Rolling Compensation" method to "compensate" the sensors (alignment targets or head units). Do not use this "Rolling Compensation" method.
- Use the "Jacking Compensation Method". After installing the alignment targets or head units, raise the vehicle and rotate the wheels 1/2 turn both ways.
- See Instructions in the alignment machine you're using for more information.

ADJUSTMENT

Camber, Caster and Kingpin Inclination Angles

CAUTION:

Camber, caster, kingpin inclination angles cannot be adjusted.

FRONT COIL SPRING AND STRUT

< ON-VEHICLE REPAIR >

ON-VEHICLE REPAIR

FRONT COIL SPRING AND STRUT

Removal and Installation

INFOID:000000003895022

REMOVAL

1. Remove tire using power tool.
2. Remove brake caliper and reposition aside using wire. Refer to [BR-31, "Removal and Installation of Brake Caliper and Rotor"](#).

CAUTION:

Avoid depressing brake pedal with brake caliper removed.

3. Remove wheel sensor electrical harness from strut. Refer to [BRC-100, "Removal and Installation"](#).
4. Remove brake hose lock plate.
5. Remove steering knuckle to strut bolts and nuts. Refer to [FSU-13, "Exploded View"](#).
6. Remove bolt on strut tower bar, then bolts on strut tower and remove strut from vehicle.

INSPECTION AFTER REMOVAL

Check the strut for any oil leakage or other damage and replace as necessary.

INSTALLATION

Installation is in the reverse order of removal.

- Refer to [FSU-13, "Exploded View"](#) for tightening torque.
- Be sure arrows on strut mount insulator and spring upper seat are positioned as shown. Also be sure notch in strut spacer is positioned as shown. Then install strut.
- Assemble upper mounting plate with its notch facing toward the outside.

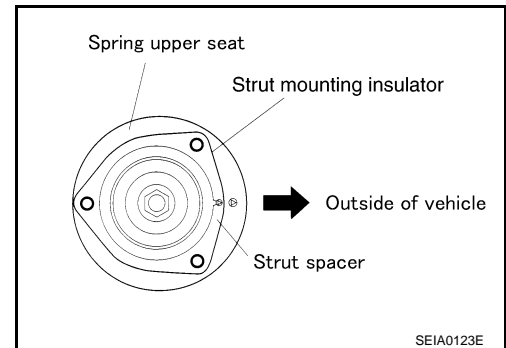

TRANSVERSE LINK

< ON-VEHICLE REPAIR >

TRANSVERSE LINK

Removal and Installation

INFOID:000000003895023

REMOVAL

1. Remove tire using power tool.
2. Remove steering knuckle from transverse link. Refer to [FSU-13, "Exploded View"](#).
3. Remove mounting nuts and washers on lower portion of stabilizer connecting rod.
4. Slightly loosen transverse link mounting bolts.
5. Remove transverse link bolts and nuts, and remove transverse link from suspension member.

INSPECTION AFTER REMOVAL

Visual Inspection

Check transverse link and bushing for deformation, cracks, and other damage. Replace the entire transverse link assembly if cracks, deformation or any other damage is found.

Ball Joint Inspection

CAUTION:

Before measurement, move the ball joint at least ten times by hand to check for smooth movement.

Swing Torque Inspection

- Hook spring scale at cotter pin mounting hole. Confirm spring scale measurement value is within specifications when ball stud begins moving.

Swing torque:

0.50 - 3.4 N·m (0.06 - 0.34 kg·m, 5 - 30 in·lb)

Measurement on spring balance:

7.94 - 53.97 N (0.81 - 5.50 kg, 1.79 - 12.2 lb)

- If the value is outside the standard, replace transverse link.

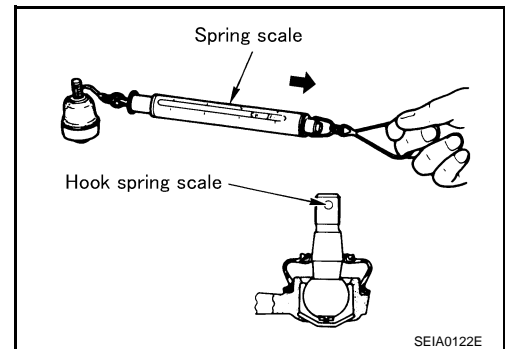

Rotating Torque Inspection

- Attach nut to ball stud. Check that rotating torque is within specifications using Tool.

Tool number : ST3127S000 (J-25765-A)

Turning torque:

0.50 - 3.4 N·m (0.06 - 0.34 kg·m, 5 - 30 in·lb)

- If the value is outside the standard, replace transverse link.

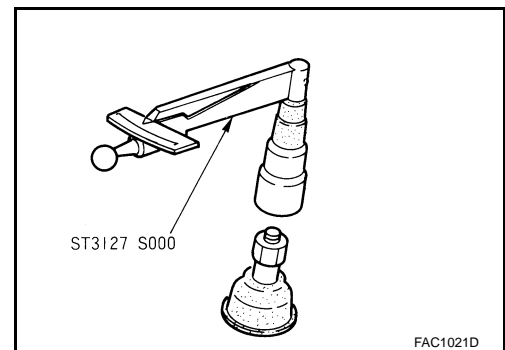

Axial Endplay Inspection

- Move tip of ball joint in axial direction to check for looseness.

Axial endplay : 0.1 mm (0.004 in) or less

- If any looseness is noted, replace transverse link.

INSTALLATION

Installation is in the reverse order of removal.

- Refer to [FSU-13, "Exploded View"](#) for tightening torque.
- Tighten transverse link bolts with vehicle unladen and all four tires on flat, level ground.
- After installation, check wheel alignment. Refer to [FSU-7, "Inspection and Adjustment"](#).

FRONT STABILIZER

< ON-VEHICLE REPAIR >

FRONT STABILIZER

Removal and Installation

INFOID:000000003895024

REMOVAL

1. Remove steering gear and linkage. Refer to [ST-23. "Removal and Installation"](#).
2. Remove nuts on upper portion of stabilizer connecting rod.

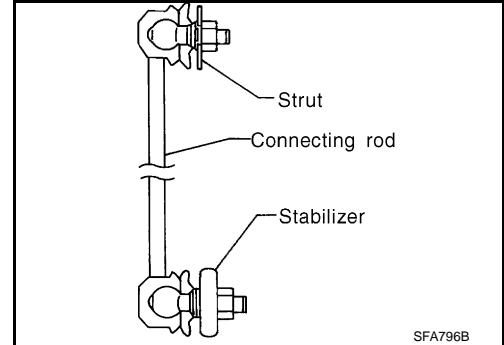

3. Remove stabilizer clamp bolts.
4. Remove stabilizer from the vehicle.

INSPECTION AFTER REMOVAL

Check stabilizer, connecting rod, bushing and clamp for deformation, cracks and damage, and replace if necessary.

INSTALLATION

Installation is in the reverse order of removal. Refer to [FSU-13. "Exploded View"](#).

- When installing stabilizer, make sure that notch (A) in stabilizer clips face front.
- Make sure the slit (B) in surface of stabilizer bushings face rear.
- ←: Front.

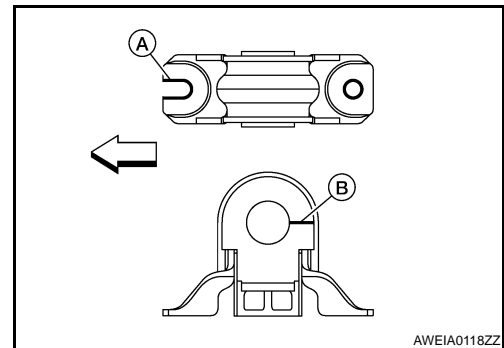

- Stabilizer uses pillow ball type connecting rod. Position ball joint with case on pillow ball head parallel to stabilizer.

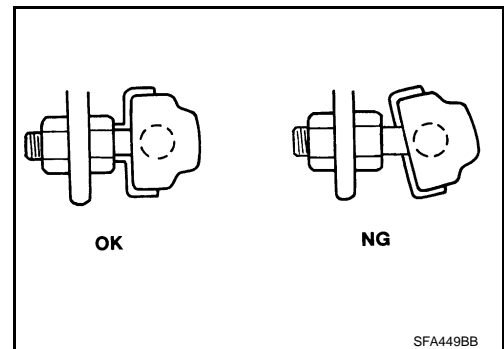

STEERING KNUCKLE

< ON-VEHICLE REPAIR >

STEERING KNUCKLE

Removal and Installation

INFOID:000000004391578

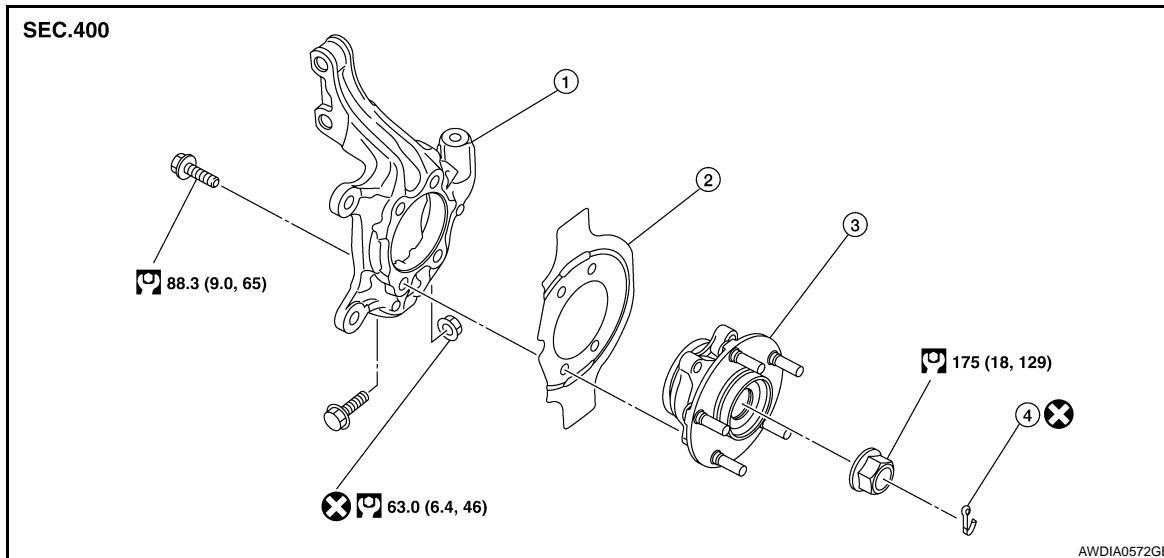

1. Steering knuckle
2. Splash guard
3. Wheel hub and bearing assembly
4. Cotter pin

REMOVAL

1. Remove front wheel hub and bearing assembly. Refer to [FAX-8, "Removal and Installation"](#).
2. Remove steering linkage from steering knuckle. Refer to [ST-23, "Removal and Installation"](#).
3. Remove steering knuckle lower pinch bolt.
4. Remove steering knuckle to strut bolts, then remove steering knuckle. Refer to [FSU-13, "Exploded View"](#).

INSPECTION AFTER REMOVAL

Check for deformity, cracks and damage on each part, replace if necessary.

INSTALLATION

Installation is in the reverse order of removal.

CAUTION:

Do not reuse non-reusable parts.

FRONT SUSPENSION ASSEMBLY

< REMOVAL AND INSTALLATION >

REMOVAL AND INSTALLATION

FRONT SUSPENSION ASSEMBLY

Exploded View

INFOID:000000003895025

SEC. 400 • 401 • 406

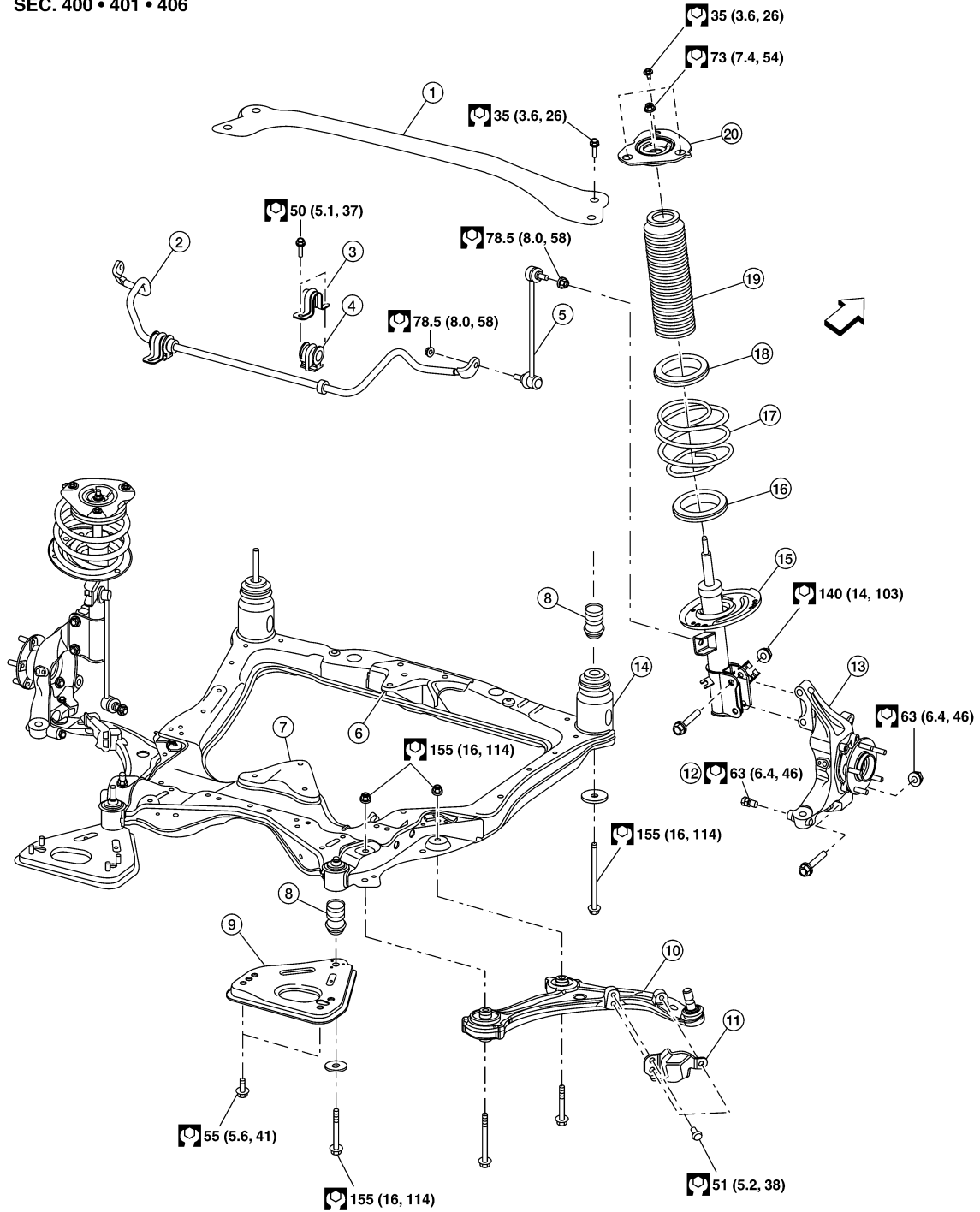

A
B
C
D
F
G
H
I
J
K
L
M
N
O
P

FSU

FRONT SUSPENSION ASSEMBLY

< REMOVAL AND INSTALLATION >

- | | | |
|---------------------------|--------------------------------|------------------------------|
| 1. Strut tower bar | 2. Stabilizer bar | 3. Stabilizer clamp |
| 4. Stabilizer bushing | 5. Connecting rod | 6. Front mount bracket |
| 7. Rear mount bracket | 8. Suspension member insulator | 9. Member pin stay |
| 10. Transverse link | 11. Steering stop plate | 12. Steering stop |
| 13. Steering knuckle | 14. Front suspension member | 15. Strut |
| 16. Coil spring | 17. Spring seat/strut bearing | 18. Dust cover/jounce bumper |
| 19. Strut mount insulator | ⇐ Front | |

Removal and Installation

INFOID:000000003895026

REMOVAL

- Engine, transmission and suspension member must be removed as an assembly. Refer to [EM-96, "Removal and Installation"](#).
- Once removed as an assembly, lift engine and transmission off suspension member using suitable tool.

INSTALLATION

Installation is in the reverse order of removal.

- Refer to [FSU-13, "Exploded View"](#) for tightening torque.
- After installation, perform final tightening of each part under unladen conditions with tires on ground. Check wheel alignment. Refer to [FSU-7, "Inspection and Adjustment"](#).

FRONT COIL SPRING AND STRUT

< DISASSEMBLY AND ASSEMBLY >

DISASSEMBLY AND ASSEMBLY

FRONT COIL SPRING AND STRUT

Disassembly and Assembly

INFOID:000000003895027

DISASSEMBLY

1. Install Tool to strut and secure it in a vise.

Tool number : ST35652000 (—)

CAUTION:

When installing Tool, wrap a shop cloth around strut to protect it from damage.

2. Slightly loosen piston rod lock nut.

WARNING:

Do not remove piston rod lock nut completely. If it is removed completely, the coil spring can jump out and may cause serious damage or injury.

3. Compress coil spring using a commercially available spring compressor.

WARNING:

Make sure that the pawls of the two spring compressors are firmly hooked on the spring. The spring compressors must be tightened alternately so as not to tilt the spring.

4. Making sure coil spring is free between upper and lower seats, then remove piston rod lock nut.
5. Remove small parts on strut.
 - Strut mount insulator, spring upper seat/strut bearing. Then remove coil spring.
6. Remove dust cover/jounce bumper from spring upper seat.
7. Gradually release spring compressor (commercial service tool), and remove coil spring.

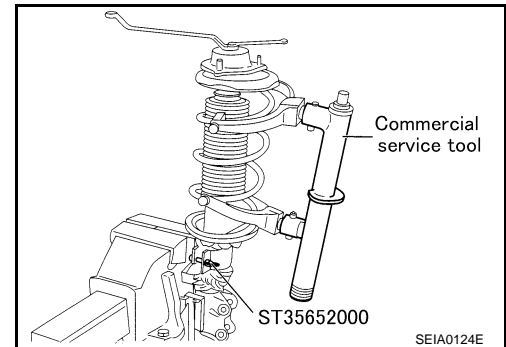

ASSEMBLY

1. Compress coil spring using a spring compressor (commercial service tool), and install it onto the strut.

CAUTION:

Face tube side of coil spring downward. Align lower end to spring seat as shown.

WARNING:

Be sure spring compressor is securely attached to coil spring. Compress coil spring.

2. Install dust cover/jounce bumper to strut mount insulator.

CAUTION:

- **Be sure to install dust cover/jounce bumper to spring upper seat securely.**
- **When installing dust cover/jounce bumper, use soapy water. Do not use machine oil or other lubricants.**

3. Install small parts to the strut.

- Spring upper seat/strut bearing and strut mount insulator. Temporarily install piston rod lock nut.

CAUTION:

Do not reuse piston rod lock nut.

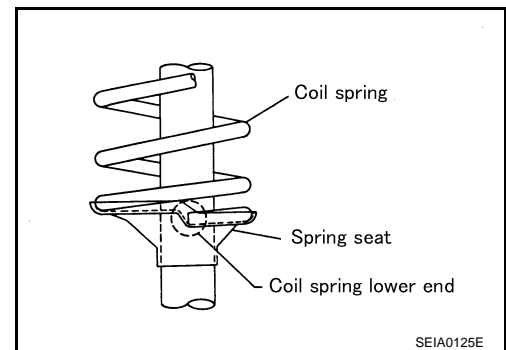

FRONT COIL SPRING AND STRUT

< DISASSEMBLY AND ASSEMBLY >

4. Be sure tab (A) on spring upper seat/strut bearing is positioned as shown.

A : Tab
⇐ : Vehicle front

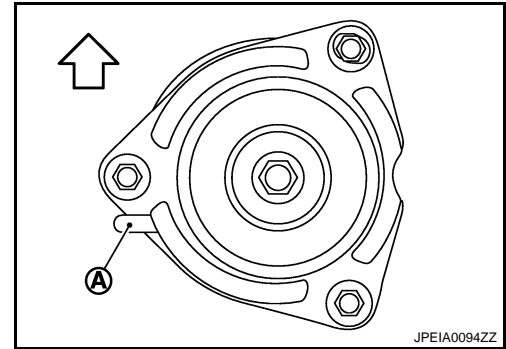

5. Be sure coil spring is properly set in spring rubber seat. Gradually release spring compressor.
CAUTION:
Be sure upper rubber seat is properly aligned to spring upper seat and coil spring.
6. Tighten piston rod lock nut to the specified torque.
7. Remove Tool from strut.

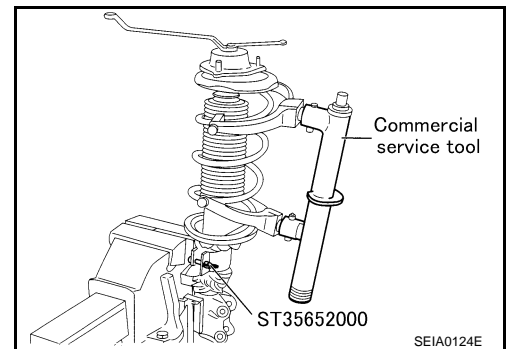

Inspection

INSPECTION AFTER DISASSEMBLY

Strut

- Check strut for deformation, cracks, and damage, and replace if necessary.
- Check piston rod for damage, uneven wear, and distortion, and replace if necessary.
- Check welded and sealed areas for oil leakage, and replace if necessary.

Insulator and Rubber Parts

Check strut mount insulator for cracks and rubber parts for wear. Replace them if necessary.

Coil Spring

Check for cracks, wear, and damage, and replace if necessary.

INFOID:000000003895028

SERVICE DATA AND SPECIFICATIONS (SDS)

< SERVICE DATA AND SPECIFICATIONS (SDS)

SERVICE DATA AND SPECIFICATIONS (SDS)

SERVICE DATA AND SPECIFICATIONS (SDS)

Wheel Alignment (Unladen*)

INFOID:000000003895029

Market			USA/Canada		Mexico	
Tire size			245/45R18	245/40R19	245/45R18	245/40R19
Camber Degree minute (Decimal degree)	LH	Minimum	-1°5' (-1.10°)	-1°10' (-1.15°)	-0°55' (-0.95°)	
		Nominal	-0°20' (-0.35°)	-0°40' (-0.65°)	-0°10' (-0.20°)	
		Maximum	0°25' (0.40°)	0°20' (0.35°)	0°35' (0.55°)	
	RH	Minimum	-1°20' (-1.35°)	-1°25' (-1.40°)	-1°10' (-1.20°)	
		Nominal	-0°35' (-0.60°)	-0°40' (-0.65°)	-0°25' (-0.45°)	
		Maximum	0°10' (0.15°)	0°05' (0.10°)	0°20' (0.30°)	
Maximum left and right difference			-0°15' ± 0°33' (-0.25° ± 0.55°)			
Caster Degree minute (Decimal degree) Against ground surface	Minimum		4°10' (4.20°)	4°15' (4.25°)	3°45' (3.75°)	
	Nominal		4°55' (4.95°)	5°00' (5.00°)	4°30' (4.50°)	
	Maximum		5°40' (5.70°)	5°45' (5.75°)	5°15' (5.25°)	
	Maximum left and right difference		0°33' (0.55°)			
Kingpin offset Degree minute (Decimal degree)	Minimum		13°40' (13.65°)		13°20' (13.35°)	
	Nominal		14°25' (14.40°)		14°05' (14.10°)	
	Maximum		15°10' (15.15°)		14°50' (14.85°)	

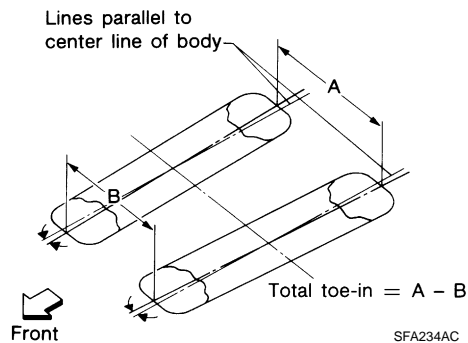

Total toe-in	Distance (A - B)	Minimum	0 mm
		Nominal	1 mm
		Maximum	2 mm
Wheel turning angle		Refer to ST-33, "Steering Angle"	

★: Fuel, radiator coolant and engine oil full. Spare tire, jack, hand tools and mats in designated positions.

Ball Joint

INFOID:000000003895030

Swing torque	0.50 - 3.4 N·m (0.06 - 0.34 kg·m, 5 - 30 in·lb)
Measurement on spring balance (cotter pinhole position)	7.94 - 53.97 N (0.81 - 5.50 kg, 1.79 - 12.2 lb)
Turning torque	0.50 - 3.4 N·m (0.06 - 0.34 kg·m, 5 - 30 in·lb)
Axial endplay	0.1 mm (0.004 in) or less

SERVICE DATA AND SPECIFICATIONS (SDS)

< SERVICE DATA AND SPECIFICATIONS (SDS)

Wheelarch Height (Unladen*1)

INFOID:000000003895031

Unit: mm (in)

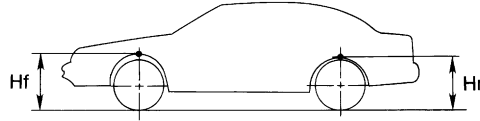

SFA818A

Market	USA/Canada			Mexico	
	P245/45R18 *2	P245/45R18 *3	P245/40R19	P245/45R18	P245/40R19
Tire size	P245/45R18 *2	P245/45R18 *3	P245/40R19	P245/45R18	P245/40R19
Front (Hf)	721 (28.39)	721 (28.39)	724 (28.50)	730 (28.74)	733 (28.86)
Rear (Hr)	736 (28.98)	734 (28.90)	736 (28.98)	754 (29.68)	757 (29.80)

*1: Fuel, engine coolant and engine oil full. Spare tire, jack, hand tools and mats in designated positions.

*2: Without top load sunroof

*3: With top load sunroof